

ITEM NO.	PART NUMBER	DESCRIPTION	QTY.
1	11003	SLEEVE MOUNT, WALL MT WIDESPREAD	2
2	3-127/00	PB WALL TUB, 291 EDGE SERIES	1
	10939/00	ESCUTCHEON, WIDESPREAD	1
	92158	DOWEL PIN, 1/8" X 3/8"L	2
	90131	O-RING, 1-11/16ID X 3/32THK. AS-568-131	1
	2-096/00	SUB-ASSY, WALL LAV 291 EDGE SERIES	1
	11010/00	SPOUT, WALL MOUNT	1
	11002/00	NIPPLE, 1/2" BRAZE BUNG	1
3	3-131/00	HANDLE CUBE 291 EDGE SERIES. NO LETTER	2
	10937/00	ESCUTCHEON, HANDLE EDGE SERIES	1
	11013/00	HANDLE. SQUARE/CUBE NO LETTER. EDGE SERIES	1
	92176	WEAR WASHER	1
	92005	SET SCREW, CUP PT 6-32UNC THREAD 3/16"L	1
	92008	SET SCREW, CUP POINT 8-32	1
4	90029	O-RING, 1-5/8"ID X 1-3/4"OD X 1/16"THK. AS-568-029	2

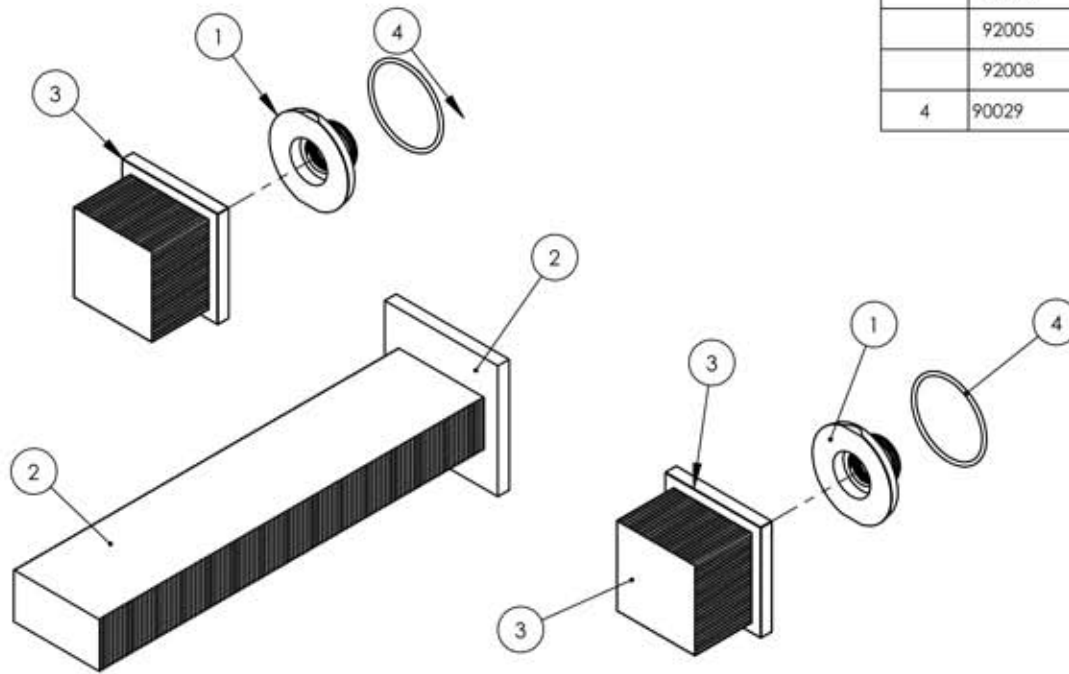

ZONE	REV.	DESCRIPTION	DATE	APPROVED
REVISIONS				
1261 LOGAN AVENUE COSTA MESA, CALIFORNIA 92626 PHONE: 714.361.4800 FAX: 714.617.3120		PHYL RICH®	<b>PROPRIETARY AND CONFIDENTIAL</b> <small>THE INFORMATION CONTAINED IN THIS DRAWING IS THE SOLE PROPERTY OF RSS MANUFACTURING. ANY REPRODUCTION IN PART OR AS A WHOLE WITHOUT THE WRITTEN PERMISSION OF RSS MANUFACTURING IS PROHIBITED.</small>	
Defining Luxury Since 1959				

-	-	INTERPRET GEOMETRIC DIMENSIONING & TOLERANCING IN ACCORDANCE WITH ASME Y14.5-2009 & ASME Y14.41-2003 STANDARDS. UNLESS OTHERWISE SPECIFIED, DIMENSIONS ARE IN INCHES. TOLERANCES ARE:		
NEXT ASSY	USED ON	FRACTIONS ±1/64"	DECIMALS X.X: ±.1 X.XX: ±.01 X.XXX: ±.005	ANGULAR ±.5°
APPLICATION		MATERIAL	NAME	DATE
FINISH		DRAWN	6/3/2013	
DO NOT SCALE DRAWING		CHECKED		

WALL TUB SET TRIM, CUBE HANDLE, STRIA SERIES			
SIZE	ASM/PRT NO.	REV	
A	291-59/00		
SCALE: 1:3	WEIGHT: lbs.	SHEET 1 OF 2	

5

4

3

2

1